

General Fitting Instructions

Selbys

SWAYBARS by WHITELINE

When fitting sway bars be sure to follow the procedures set out in the instruction sheets supplied with the bar. Pay particular attention to tensioning link bush nuts as it is critical that they are not tightened to the point that they distort the bush.

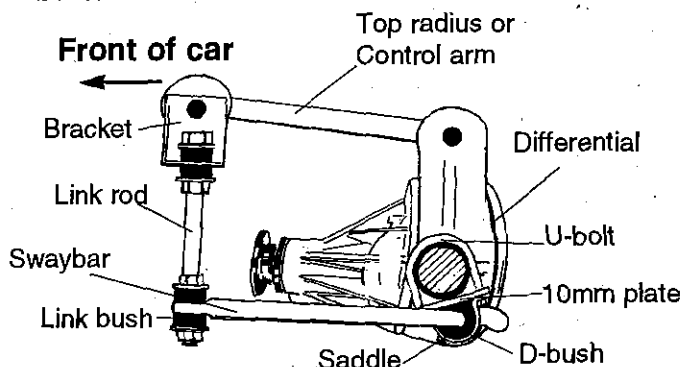

1. Position the bar and D-bushes under the differential housing so that the arms of the bar point forward to the front of the vehicle.

2. Place the U-bolts over the differential making sure that the brake lines are clear. Using the 10mm plates, D-bushes and saddles attach the bar to the differential (as shown in illustration above).

Do not tighten nuts at this stage as the bar needs to be adjusted and tightened after the following is completed.

3. Undo the nut that holds the upper trailing arms to the floor pan / chassis bracket. Place the angle bracket supplied on to the bolt, replace nuts and tighten.

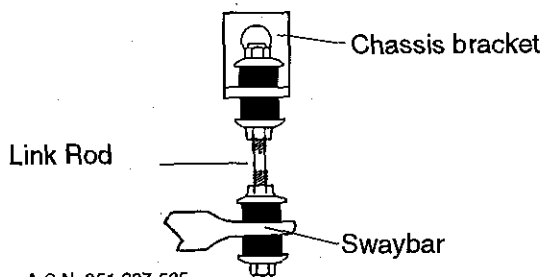

Assemble the links to the angle brackets and to the swaybar as shown in diagrams below.

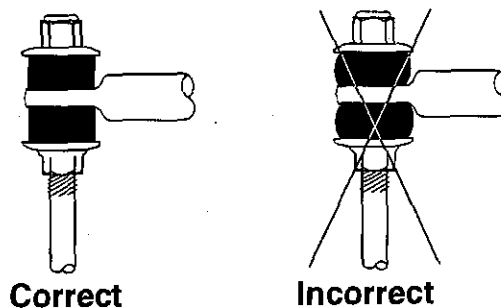

4. Ensuring that the links are vertical tighten U-bolt nuts. Do not over tighten the link bush nuts.

PLEASE DRIVE CAREFULLY AND ACCUSTOM YOURSELF TO THE FLATTER RIDE AND IMPROVED HANDLING CHARACTERISTICS OF YOUR VEHICLE